

Agilent 81663A DFB Laser Source Module

User's Guide

Notices

© 2000-2010 Agilent Technologies, Inc.

No part of this manual may be reproduced in any form or by any means (including electronic storage and retrieval or translation into a foreign language) without prior agreement and written consent from Agilent Technologies, Inc. as governed by United States and international copyright laws.

Manual Part Number

81661-90A15

Edition

Eighth Edition, May 2010

Seventh Edition, December 2007

Sixth Edition, June 2005

Seventh Edition, February 2002

Fourth Edition, August 2001

Third Edition, January 2001

Second Edition, October 2000

First Edition, June 2000

Agilent Technologies Deutschland GmbH
Herrenberger Str. 130
71034 Böblingen, Germany.

Warranty

The material contained in this document is provided “as is,” and is subject to being changed without notice in future editions. Further, to the maximum extent permitted by applicable law, Agilent Technologies disclaims all warranties of merchantability and fitness for a particular purpose. Agilent Technologies shall not be liable for errors or for incidental or consequential damages in connection with the furnishing, use, or performance of this document or of any of the products to which it pertains. Should Agilent Technologies have a written contract with the user and should any of the contract terms conflict with these terms the contract terms shall control.

Technology Licenses

The hardware and/or software described in this document are furnished under a license and may be used or copied only in accordance with the terms of such license.

Restricted Rights Legend

If Software is for use in the performance of a U.S. Government prime contract or sub-contract, Software is delivered and licensed as “Commercial computer software” as defined in DFAR 252.227-7014 (June 1995), or as a “commercial item” as defined in FAR 2.101(a) or as “Restricted computer software” as defined in FAR 52.227-19 (June 1987) or any equivalent agency regulation or contract clause. Use, duplication or disclosure of Software is subject to Agilent Technologies’ standard

commercial license terms, and non-DOD Departments and Agencies of the U.S. Government will receive no greater than Restricted Rights as defined in FAR 52.227-19(c)(1-2) (June 1987). U.S. Government users will receive no greater than Limited Rights as defined in FAR 52.227-14 (June 1987) or DFAR 252.227-7015 (b)(2) (November 1995), as applicable in any technical data.

Safety Notices

CAUTION

A **CAUTION** notice denotes a hazard. It calls attention to an operating procedure, practice, or the like that, if not correctly performed or adhered to, could result in damage to the product or loss of important data. Do not proceed beyond a **CAUTION** notice until the indicated conditions are fully understood and met.

WARNING

A **WARNING** notice denotes a hazard. It calls attention to an operating procedure, practice, or the like that, if not correctly performed or adhered to, could result in personal injury or death. Do not proceed beyond a **WARNING** notice until the indicated conditions are fully understood and met.

Agilent Technologies Sales and Service Offices

For more information about Agilent Technologies test and measurement products, applications, services, and for a current sales office listing, visit our web site:

<http://www.agilent.com/comms/lightwave>

You can also contact one of the following centers and ask for a test and measurement sales representative.

United States:	(tel) 800 829 4444 (fax) 800 829 4433
Canada:	(tel) 877 894 4414 (fax) 800 746 4866
China	(tel) 800 810 0189 (fax) 800 820 2816
Europe:	(tel) 31 20 547 2111
Japan:	(tel) (81) 426 56 7832 (fax) (81) 426 56 7840
Korea	(tel) (080) 769 0800 (fax) (080) 769 0900
Latin America:	(tel) (305) 269 7500
Taiwan:	(tel) 0800 047 866 (fax) 0800 286 331
Other Asia Pacific countries:	(tel) (65) 6375 8100 (fax) (65) 6755 0042 Email: tm_ap@agilent.com

Table of Contents

Agilent Technologies Sales and Service Offices 3

1 Getting Started with DFB Laser Sources

Safety Considerations	8
Safety Symbols	8
Initial Inspection	8
Line Power Requirements	9
Operating Environment	9
Storage and Shipment	9
Environmental Information	9
Initial Safety Information for the DFB Laser Source Module	10
Laser Safety Labels	10
What is a DFB Laser Source Module?	11
A Description of the Front Panel	11
Optical Output	11
Operation Note	13
Maintaining Wavelength Accuracy Below Maximum Power	13

2 Accessories

Recommended Connector Interfaces	16
Wavelength Options	16

3 Performance Tests

Equipment Required	18
Test Record	18
Test Failure	18
Instrument Specification	18
Performance Test Instructions	19
All Wavelength Tests	19
Wavelength Repeatability Test	19

Wavelength Stability Test	20
Test Records	21

4 Cleaning Information

Safety Precautions	26
Why is it important to clean optical devices?	27
What do I need for proper cleaning?	28
Standard Cleaning Equipment	28
Additional Cleaning Equipment	31
Preserving Connectors	33
Cleaning Instrument Housings	34
Which Cleaning Procedure should I use ?	35
How to clean connectors	36
How to clean connector adapters	38
How to clean connector interfaces	39
How to clean bare fiber adapters	40
How to clean lenses	41
How to clean instruments with a fixed connector interface	42
How to clean instruments with an optical glass plate	43
How to clean instruments with a physical contact interface	44
How to clean instruments with a recessed lens interface	45
How to clean optical devices which are sensitive to mechanical stress and pressure	46
How to clean metal filters or attenuator gratings	47
Additional Cleaning Information	48
How to clean bare fiber ends	48
How to clean large area lenses and mirrors	48
Other Cleaning Hints	51

5 Specifications

Definition of Terms	54
DFB Source Module Specifications	57
Supplementary Performance Characteristics	57

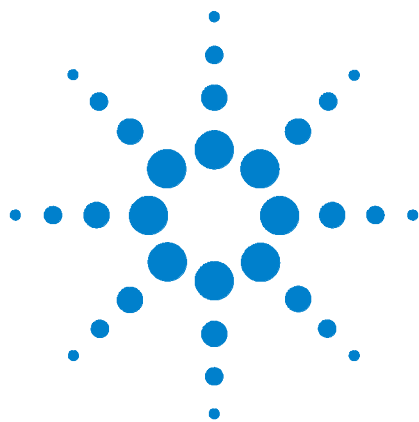

1 Getting Started with DFB Laser Sources

This chapter introduces the features of the Agilent 81663A DFB Laser Source Module.



Safety Considerations

The following general safety precautions must be observed during all phases of operation, service, and repair of this instrument. Failure to comply with these precautions or with specific warnings elsewhere in this manual violates safety standards of design, manufacture, and intended use of the instrument. Agilent Technologies assumes no liability for the customer's failure to comply with these requirements.

Before operation, review the instrument and manual, including the safety page, for safety markings and instructions. You must follow these to ensure safe operation and to maintain the instrument in safe condition.

WARNING

The WARNING sign denotes a hazard. It calls attention to a procedure, practice or the like, which, if not correctly performed or adhered to, could result in injury or loss of life. Do not proceed beyond a WARNING sign until the indicated conditions are fully understood and met.

Safety Symbols



The apparatus will be marked with this symbol when it is necessary for the user to refer to the instruction manual in order to protect the apparatus against damage.



Hazardous laser radiation.

Initial Inspection

Inspect the shipping container for damage. If there is damage to the container or cushioning, keep them until you have checked the contents of the shipment for completeness and verified the instrument both mechanically and electrically.

The Performance Tests give procedures for checking the operation of the instrument. If the contents are incomplete, mechanical damage or defect is apparent, or if an instrument does not pass the operator's checks, notify the nearest Agilent Technologies Sales/Service Office.

WARNING

To avoid hazardous electrical shock, do not perform electrical tests when there are signs of shipping damage to any portion of the outer enclosure (covers, panels, etc.).

WARNING

You ***MUST*** return instruments with malfunctioning laser modules to an Agilent Technologies Service Center for repair and calibration.

Line Power Requirements

The Agilent 81663A DFB Laser Source Module operates when installed in the Agilent 8163A/B Lightwave Multimeter, Agilent 8164A/B Lightwave Measurement System, or Agilent 8166A/B Lightwave Multichannel System.

Operating Environment

The safety information in the Agilent 8163A/B Lightwave Multimeter, Agilent 8164A/B Lightwave Measurement System, and Agilent 8166A/B Lightwave Multichannel System User's Guide summarizes the operating ranges for the Agilent 81663A DFB Laser Source Module. In order for this module to meet specifications, the operating environment must be within the limits specified for the mainframe.

Storage and Shipment

The module can be stored or shipped at temperatures between -40°C and $+70^{\circ}\text{C}$. Protect the module from temperature extremes that may cause condensation within it.

Environmental Information



This product complies with the WEEE Directive (2002/96/EC) marking requirements. The affixed label indicates that you must not discard this electrical/ electronic product in domestic household waste.

Product Category: With reference to the equipment types in the WEEE Directive Annex I, this product is classed as a "Monitoring and Control instrumentation" product.

Do not dispose in domestic household waste.

To return unwanted products, contact your local Agilent office, or see www.agilent.com/environment/product/ for more information

Initial Safety Information for the DFB Laser Source Module

The laser sources specified by this user guide are classified according to IEC 60825-1 (2001)

The laser sources comply with 21 CFR 1040.10 except for deviations pursuant to Laser Notice No. 50, dated 2001-July-26.

Table 1 DFB Laser Source Module Safety Information

	Agilent 81663A
Laser type	CW DFB Laser with built-in isolator
Wavelength range	1300 to 1650 nm see display
Max. CW output power*	<28 mW
Beam waist diameter	9 μ m
Numerical aperture	0.1
Laser Class according to IEC 60825-1 (2001)- International	1M
Max. permissible CW output power	163 mW

* Max. CW output power is defined as the highest possible optical power that the laser source can produce at its output connector

Laser Safety Labels

Laser class 1M label

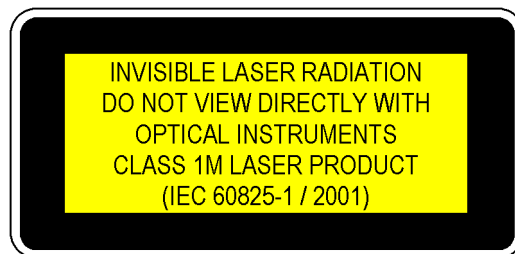

Figure 1 Class 1M Safety Label - Agilent 81663A

A sheet of laser safety labels is included with the laser module as required. In order to meet the requirements of IEC 60825-1 we recommend that you stick the laser safety labels, in your language, onto a suitable location on the outside of the instrument where they are clearly visible to anyone using the instrument.

What is a DFB Laser Source Module?

A distributed feedback (DFB) laser is a highly-coherent laser source that emits radiation in a narrow spectral width. The Agilent Technologies DFB laser source module may be tuned within a specific wavelength range, the current wavelength is displayed on the user interface of your mainframe. The center wavelength your module supports is displayed on the front panel, see Figure 2.

A Description of the Front Panel

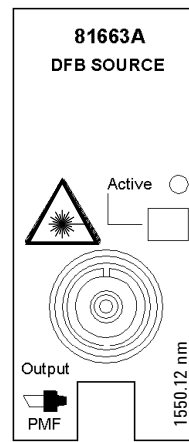

Figure 2 Front Panel of DFB Laser Source Module

To insert the module into your mainframe see your mainframe's User's Guide.

How to Enable/Disable Laser Output

If the laser is on, the green LED on the front panel of the module is lit. If the laser is off, green LED on the front panel of the module is unlit. You can switch the module by pressing the Active button on the front panel of the module.

Optical Output

Polarization Maintaining Fiber

The Agilent 81663A DFB Laser Source module is equipped with a polarization maintaining fiber (PMF) as standard, the PMF is aligned to maintain the state of polarization.

The fiber is of Panda type, with TE mode in the slow axis in line with the connector key. A well defined state of polarization ensures constant measurement conditions.

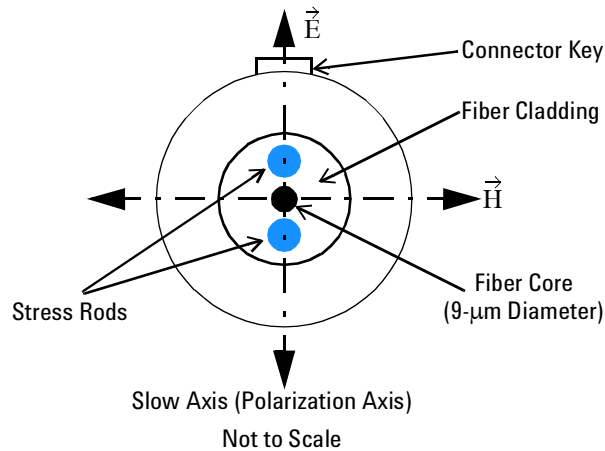

Figure 3 PMF Output Connector

Angled Contact Connectors

The Agilent 81663A DFB Laser Source module is equipped with an angled contact optical output connector as standard.

Angled contact connector helps you to control return loss. With angled fiber endfaces, reflected light tends to reflect into the cladding, reducing the amount of light that reflects back to the source.

CAUTION

CAUTION

If the contact connector on your instrument is angled, you can only use cables with angled connectors with the instrument.



Figure 4 Angled Contact Connector Symbols

Figure 4 shows the symbol that tells you the contact connector of your tunable laser module is angled. The angled contact connector symbol for an optical output equipped with a PMF is colored green.

Operation Note

Maintaining Wavelength Accuracy Below Maximum Power

The wavelength accuracy of your DFB Laser Source module is optimized when you set power to the maximum available for your module. As you reduce power, the drive current through the laser diode changes; this can mean that the actual output wavelength may differ from the wavelength displayed on the user interface of your mainframe.

To ensure wavelength accuracy at less than maximum power you should perform the steps listed below. You will need to use a wavelength meter, we recommend the Agilent 86120C Multi-Wavelength Meter.

- 1 Set up your equipment as displayed in Figure 5.

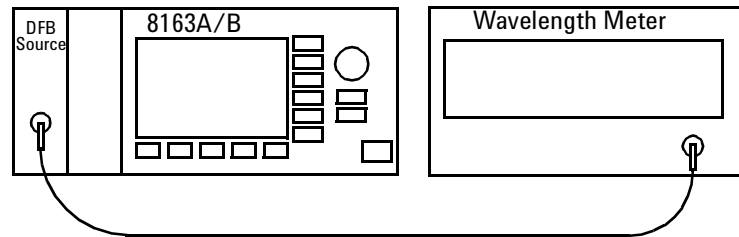

Figure 5 Wavelength Accuracy Setup

- 2 On the user interface of your Agilent 8163A/B Lightwave Multimeter, move to the DFB source module channel and perform the following steps:
 - a Move to [P], and press *Enter*.
 - b Set the power value to the maximum power for the module. The maximum power for the 81663A is 13 dBm. Since the maximum displayed power of the 86120C is 10 dBm, we recommend you use a power splitter or attenuator between the source and the wavelength meter.
 - c Move to [λ], and press *Enter*.
 - d Set the wavelength to the value you require.
 - e Enable the laser by pressing the button on the front panel of the module.
- 3 Allow your wavelength meter to settle to a stable wavelength value. Check the displayed value against the value displayed on the user interface of your 8163A/B Lightwave Multimeter.

- 4 On the user interface of your 8163A/B Lightwave Multimeter, perform the following steps:
 - a Move to [P], and press *Enter*.
 - b Reduce the power for the module.
- 5 Allow your wavelength meter to settle to a stable wavelength value. If the displayed value is not accurate enough for your application, on the user interface of your 8163A/B Lightwave Multimeter, perform the following steps:
 - a Move to [λ], and press *Enter*.
 - b Adjust the wavelength value until the wavelength meter displays the wavelength you require. Allow time for the wavelength meter to settle.

NOTE

The DFB Laser Source channel will display a wavelength value that differs from the value displayed by the wavelength meter. The wavelength meter displays the correct value.

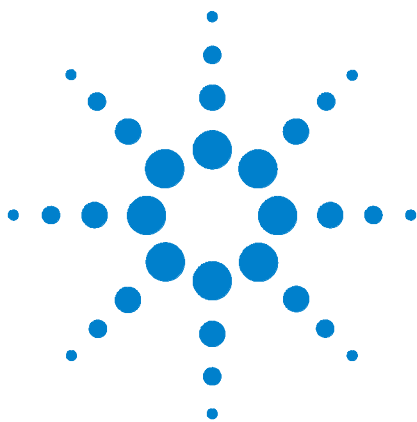

2 Accessories

The Agilent 81663A DFB Laser Source Module is available in various configurations for the best possible match to the most common applications.

This chapter provides information on the available options and accessories.



Recommended Connector Interfaces

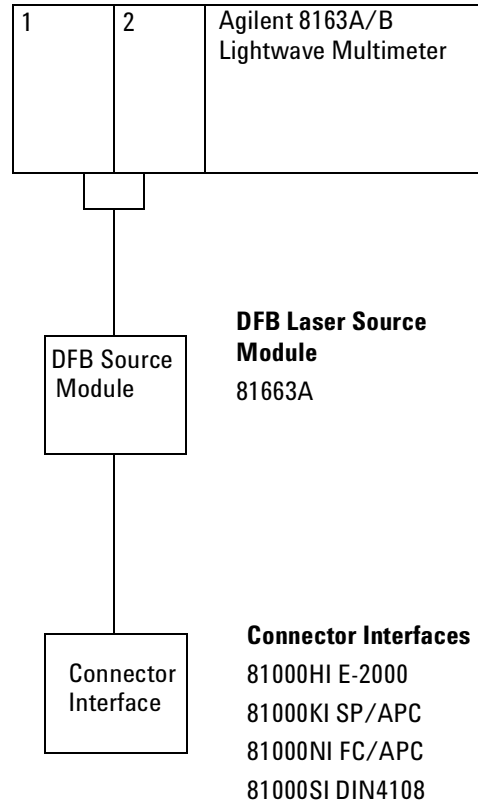
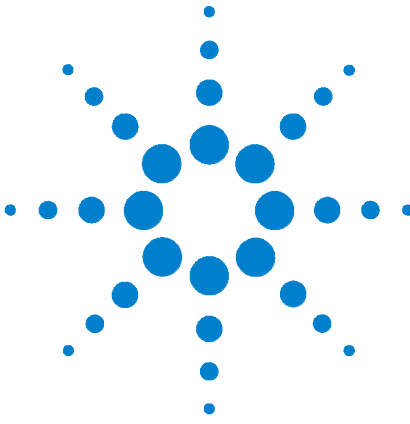

Figure 6 Recommended Connector Interfaces

Wavelength Options

Agilent 81663A Option Number	Center Wavelength [nm]
#131	1310
#149	1490
#151	1510
#155	1550
#162	1625



3 Performance Tests

The procedures in this section test the optical performance of the instrument. The complete specifications to which the Agilent 81663A DFB Laser Source Module is tested are given in *"Specifications"* on page 53. All tests can be performed without access to the interior of the instrument. The performance tests refer specifically to tests carried out with APC connectors.



Equipment Required

Equipment required for the performance test is listed below.

Instrument/Accessory	Recommended Model	Required Characteristics	Alternative Models
Multimeter Mainframe	Agilent 8163B		Agilent 8163A, Agilent 8164A/B, Agilent 8166A/B
Wavelength Meter	Agilent 86122A		Agilent 86120C
Singlemode Fibers	Agilent 81113PC		
Connector Interfaces	Agilent 81000FI Agilent 81000SI		

Test Record

Results of the performance test may be noted in the Test Record provided at the end of the Test Procedures. The Test Record can also be used as a permanent record and may be reproduced without written permission from Agilent Technologies.

Test Failure

If the Agilent 81663A DFB Laser Source Module fails any performance test, return the instrument to the nearest Agilent Technologies Sales/Service Office for repair.

Instrument Specification

Specifications are the performance characteristics of the instrument that are certified. These specifications, listed in *"Specifications" on page 53*, are the performance standards or limits against which the Agilent 81663A DFB Laser Source Module can be tested. The specifications also list some supplemental characteristics of the Agilent 81663A DFB Laser Source Module. Supplemental characteristics should be considered as additional information.

Any changes in the specifications due to manufacturing changes, design, or traceability to the National Institute of Standards and Technology (NIST), will be covered in a manual change supplement, or revised manual. Such specifications supersede any that were previously published.

Performance Test Instructions

The performance tests given in this section include the Wavelength Repeatability Test and the Wavelength Stability Test. Perform each step in the order given, using the corresponding test equipment.

NOTE

- Make sure that all the optical connections used in the test setups given in the procedures are dry and clean. Refer to the "Cleaning Information" on page 25.
- DO NOT USE INDEX MATCHING OIL.
- Turn the instruments on, enable the laser and allow the instruments to warm up for at least 60 minutes.
- The ambient temperature must be constant (± 1 K) during the tests.

All Wavelength Tests

Make sure that the cable connector, detectors and adapters are clean.

- 1 Connect the output of the DFB Laser Source Module to the input of the wavelength meter.

General Settings for the wavelength meter

Set up the wavelength meter as follows. Please refer to the user guide for the wavelength meter if you need further instructions.

- 2 Set the display to show peak wavelength.
- 3 Set the medium to *Vacuum*.

Wavelength Repeatability Test

- 1 Move to the DFB-Source channel of the Agilent 8163A/B 8164A/B or 8166A/B mainframe and press *Menu*.
- 2 Set the *Wavelength mode* to *Offset* and adjust the *Power* to less than the maximum displayed level of the wavelength meter. The minimum setting for the DFB power may be used.
- 3 *Close* the Menu.
- 4 Press the key beside the laser output to switch on the laser output.
- 5 Adjust the frequency offset to the first value given in the test record in column "from wavelength".

- 6 Wait until the wavelength meter has settled. Then measure the wavelength and note the result in the test record as the reference wavelength, "REF".
- 7 Set the frequency offset of the DFB Source module to any value in its range (in the test record, this is given in column "from wavelength").
- 8 Set the frequency offset of the DFB Source back to the reference frequency and wait until the Wavelength Meter has settled.
- 9 Repeat steps 5 to 8 for all frequency offsets given in the test record.
- 10 From all the wavelength measurements, pick the largest measured value and the smallest measured value.
- 11 Calculate the wavelength repeatability by subtracting the largest measured value from the smallest measured value.

Wavelength Stability Test

- 1 Move to the DFB-Source channel of the Agilent 8163A/B, 8164A/B or 8166A/B Lightwave Multimeter Mainframe and press *Menu*.
- 2 Set the *Wavelength mode* to *Offset* and adjust the *Power* to less than the maximum displayed level of the wavelength meter. The minimum setting for the DFB power may be used.
- 3 *Close* the Menu.
- 4 Press $\lambda \varnothing \lambda_0$
- 5 Press the key beside the laser output to switch on the laser output.
- 6 Every minute for 15 minutes, note the Wavelength Meter reading in the test record.
- 7 From all the wavelength measurements, pick the largest measured value and the smallest measured value.
- 8 Calculate the wavelength stability by subtracting the largest measured value from the smallest measured value.

Performance Test for the Agilent 81663A

Test Equipment Used

Page 2 of 4

	Description	Model No.	Trace No	Cal. Due Date			
1a	Lightwave Multimeter	Agilent 8163A/B	_____	_____			
1b	Multichannel System	Agilent 8166A/B	_____	_____			
1c	Measurement System	Agilent 8164A/B	_____	_____			
2a	Wavelength Meter	Agilent 81622A	_____	_____			
2b	Wavelength Meter	Agilent 86120C	_____	_____			
3	_____	_____	_____	_____			
4	_____	_____	_____	_____			
5	_____	_____	_____	_____			
6	_____	_____	_____	_____			
7	_____	_____	_____	_____			
8	_____	_____	_____	_____			
9	_____	_____	_____	_____			
10	_____	_____	_____	_____			
11	_____	_____	_____	_____			
12	_____	_____	_____	_____			
Accessories		#	Product	#	Product	#	Product
	Singemode Fibers	1	81113PC	1			
	Connector Interfaces	1	81000FI	1	81000SI		

Performance Test for the Agilent 81663A

Page 3 of 4

Test Number	Test Description	Minimum Specification.	Result	Maximum Specification.	Measurement Uncertainty
1	Wavelength Repeatability measured at _____ nm (-50 GHz offset frequency)		nm _____	nm < 0.01 m,	
	measured at _____ nm (0 GHz offset frequency)		_____	< 0.01 m,	
	measured at _____ nm (+50 GHz offset frequency)		_____	< 0.01 m,	
2	Wavelength Stability, 15min measured at _____ nm (0 GHz offset frequency)		nm _____	nm < 0.01 m,	

Test Records

Repeatability of $\Delta f = -50 \text{ GHz}$ (= reference)	Measurement Result
Initial Setting REF =	nm
from -30 GHz to -50 GHz	nm
from -10 GHz to -50 GHz	nm
from 0 GHz to -50 GHz	nm
from +10 GHz to -50 GHz	nm
from +30 GHz to -50 GHz	nm
from +50 GHz to -50 GHz	nm
largest measured value	nm
smallest measured value	nm
Wavelength Repeatability	nm

Repeatability of $\Delta f = 0 \text{ GHz}$ (= reference)	Measurement Result
Initial Setting REF =	nm
from -30 GHz to -50 GHz	nm
from -10 GHz to -50 GHz	nm
from 0 GHz to -50 GHz	nm
from +10 GHz to -50 GHz	nm
from +30 GHz to -50 GHz	nm
from +50 GHz to -50 GHz	nm
largest measured value	nm
smallest measured value	nm
Wavelength Repeatability	nm

Performance Test for the Agilent 81663A

Page 4 of 4

Repeatability of $\Delta f = +50$ GHz (= reference)	Measurement Result
Initial Setting REF =	nm
from -30 GHz to -50 GHz	nm
from -10 GHz to -50 GHz	nm
from 0 GHz to -50 GHz	nm
from +10 GHz to -50 GHz	nm
from +30 GHz to -50 GHz	nm
from +50 GHz to -50 GHz	nm
largest measured value	nm
smallest measured value	nm
Wavelength Repeatability	nm

Stability of _____ nm	Measurement Result
Start Value	nm
1.	nm
2.	nm
3.	nm
4.	nm
5.	nm
6.	nm
7.	nm
8.	nm
9.	nm
10.	nm
11.	nm
12.	nm
13.	nm
14.	nm
15.	nm
largest measured value	nm
smallest measured value	nm
Wavelength Repeatability	nm

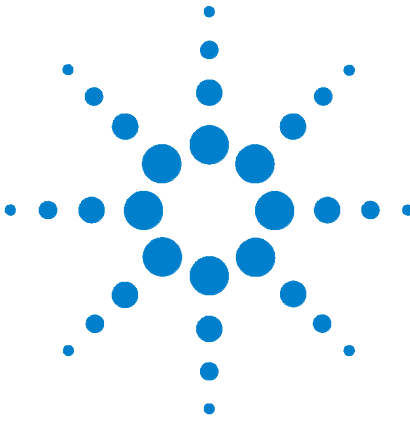

4 Cleaning Information

The following Cleaning Information contains some general safety precautions, which must be observed during all phases of cleaning. Consult your specific optical device manuals or guides for full information on safety matters.

Please try, whenever possible, to use physically contacting connectors, and dry connections. Clean the connectors, interfaces, and bushings carefully after use.

If you are unsure of the correct cleaning procedure for your optical device, we recommend that you first try cleaning a dummy or test device.

Agilent Technologies assume no liability for the customer's failure to comply with these requirements.

Cleaning Instructions for this Instrument

This Cleaning Information applies to a number of different types of Optical Equipment.

“How to clean instruments with a physical contact interface” on page 44 is particularly relevant to this module.



Safety Precautions

Please follow the following safety rules:

- Do not remove instrument covers when operating.
- Ensure that the instrument is switched off throughout the cleaning procedures.
- Use of controls or adjustments or performance of procedures other than those specified may result in hazardous radiation exposure.
- Make sure that you disable all sources when you are cleaning any optical interfaces.
- Under no circumstances look into the end of an optical device attached to optical outputs when the device is operational. The laser radiation is not visible to the human eye, but it can seriously damage your eyesight.
- To prevent electrical shock, disconnect the instrument from the mains before cleaning. Use a dry cloth, or one slightly dampened with water, to clean the external case parts. Do not attempt to clean internally.
- Do not install parts or perform any unauthorized modification to optical devices.
- Refer servicing only to qualified and authorized personnel.

Why is it important to clean optical devices?

In transmission links optical fiber cores are about 9 μm (0.00035") in diameter. Dust and other particles, however, can range from tenths to hundredths of microns in diameter. Their comparative size means that they can cover a part of the end of a fiber core, and as a result will reduce the performance of your system.

Furthermore, the power density may burn dust into the fiber and cause additional damage (for example, 0 dBm optical power in a single mode fiber causes a power density of approximately 16 million W/m^2). If this happens, measurements become inaccurate and non-repeatable.

Cleaning is, therefore, an essential yet difficult task. Unfortunately, when comparing most published cleaning recommendations, you will discover that they contain several inconsistencies. In this section, we want to suggest ways to help you clean your various optical devices, and thus significantly improve the accuracy and repeatability of your lightwave measurements.

What do I need for proper cleaning?

Some Standard Cleaning Equipment is necessary for cleaning your instrument. For certain cleaning procedures, you may also require certain Additional Cleaning Equipment.

Standard Cleaning Equipment

Before you can start your cleaning procedure you need the following standard equipment:

- Dust and shutter caps
- Isopropyl alcohol
- Cotton swabs
- Soft tissues
- Pipe cleaner
- Compressed air

Dust and shutter caps

All of Agilent Technologies' lightwave instruments are delivered with either laser shutter caps or dust caps on the lightwave adapter. Any cables come with covers to protect the cable ends from damage or contamination.

We suggest these protective coverings should be kept on the equipment at all times, except when your optical device is in use. Be careful when replacing dust caps after use. Do not press the bottom of the cap onto the fiber too hard, as any dust in the cap can scratch or pollute your fiber surface.

If you need further dust caps, please contact your nearest Agilent Technologies sales office.

Isopropyl alcohol

This solvent is usually available from any local pharmaceutical supplier or chemist's shop.

If you use isopropyl alcohol to clean your optical device, do not immediately dry the surface with compressed air (except when you are cleaning very sensitive optical devices). This is because the dust and the dirt is solved and will leave behind filmy deposits after the alcohol is evaporated. You should therefore first remove the alcohol and the dust with a soft tissue, and then use compressed air to blow away any remaining filaments.

If possible avoid using denatured alcohol containing additives. Instead, apply alcohol used for medical purposes.

Never drink this alcohol, as it may seriously damage to your health.

Do not use any other solvents, as some may damage plastic materials and claddings. Acetone, for example, will dissolve the epoxy used with fiber optic connectors. To avoid damage, only use isopropyl alcohol.

Cotton swabs

We recommend that you use swabs such as Q-tips or other cotton swabs normally available from local distributors of medical and hygiene products (for example, a supermarket or a chemist's shop). You may be able to obtain various sizes of swab. If this is the case, select the smallest size for your smallest devices.

Ensure that you use natural cotton swabs. Foam swabs will often leave behind filmy deposits after cleaning.

Use care when cleaning, and avoid pressing too hard onto your optical device with the swab. Too much pressure may scratch the surface, and could cause your device to become misaligned. It is advisable to rub gently over the surface using only a small circular movement.

Swabs should be used straight out of the packet, and never used twice. This is because dust and dirt in the atmosphere, or from a first cleaning, may collect on your swab and scratch the surface of your optical device.

Soft tissues

These are available from most stores and distributors of medical and hygiene products such as supermarkets or chemists' shops.

We recommend that you do not use normal cotton tissues, but multi-layered soft tissues made from non-recycled cellulose. Cellulose tissues are very absorbent and softer. Consequently, they will not scratch the surface of your device over time.

Use care when cleaning, and avoid pressing on your optical device with the tissue. Pressing too hard may lead to scratches on the surface or misalignment of your device. Just rub gently over the surface using a small circular movement.

Use only clean, fresh soft tissues and never apply them twice. Any dust and dirt from the air which collects on your tissue, or which has gathered after initial cleaning, may scratch and pollute your optical device.

Pipe cleaner

Pipe cleaners can be purchased from tobacconists, and come in various shapes and sizes. The most suitable one to select for cleaning purposes has soft bristles, which will not produce scratches.

There are many different kinds of pipe cleaner available from tobacco nists.

The best way to use a pipe cleaner is to push it in and out of the device opening (for example, when cleaning an interface). While you are cleaning, you should slowly rotate the pipe cleaner.

Only use pipe cleaners on connector interfaces or on feed through adapters. Do not use them on optical head adapters, as the center of a pipe cleaner is hard metal and can damage the bottom of the adapter.

Your pipe cleaner should be new when you use it. If it has collected any dust or dirt, this can scratch or contaminate your device.

The tip and center of the pipe cleaner are made of metal. Avoid accidentally pressing these metal parts against the inside of the device, as this can cause scratches.

Compressed air

Compressed air can be purchased from any laboratory supplier.

It is essential that your compressed air is free of dust, water and oil. Only use clean, dry air. If not, this can lead to filmy deposits or scratches on the surface of your connector. This will reduce the performance of your transmission system.

When spraying compressed air, hold the can upright. If the can is held at a slant, propellant could escape and dirty your optical device. First spray into the air, as the initial stream of compressed air could contain some condensation or propellant. Such condensation leaves behind a filmy deposit.

Please be friendly to your environment and use a CFC-free aerosol.

Additional Cleaning Equipment

Some Cleaning Procedures need the following equipment, which is not required to clean each instrument:

- Microscope with a magnification range about 50X up to 300X
- Ultrasonic bath
- Warm water and liquid soap
- Premoistened cleaning wipes
- Polymer film
- Infrared Sensor Card

Microscope with a magnification range about 50X up to 300X

A microscope can be found in most photography stores, or can be obtained through or specialist mail order companies. Special fiber-scopes are available from suppliers of splicing equipment.

Ideally, the light source on your microscope should be very flexible. This will allow you to examine your device closely and from different angles.

A microscope helps you to estimate the type and degree of dirt on your device. You can use a microscope to choose an appropriate cleaning method, and then to examine the results. You can also use your microscope to judge whether your optical device (such as a connector) is severely scratched and is, therefore, causing inaccurate measurements.

Ultrasonic bath

Ultrasonic baths are also available from photography or laboratory suppliers or specialist mail order companies.

An ultrasonic bath will gently remove fat and other stubborn dirt from your optical devices. This helps increase the life span of the optical devices.

Only use isopropyl alcohol in your ultrasonic bath, as other solvents may cause damage.

Warm water and liquid soap

Only use water if you are sure that there is no other way of cleaning your optical device without causing corrosion or damage. Do not use hot water, as this may cause mechanical stress, which can damage your optical device.

Ensure that your liquid soap has no abrasive properties or perfume in it. You should also avoid normal washing up liquid, as it can cover your device in an iridescent film after it has been air dried.

Some lenses and mirrors also have a special coating, which may be sensitive to mechanical stress, or to fat and liquids. For this reason we recommend you do not touch them.

If you are not sure how sensitive your device is to cleaning, please contact the manufacturer or your sales distributor.

Premoistened cleaning wipes

Use pre-moistened cleaning wipes as described in each individual cleaning procedure. Cleaning wipes may be used in every instance where a moistened soft tissue or cotton swab is applied.

Polymer film

Polymer film is available from laboratory suppliers or specialist mail order companies.

Using polymer film is a gentle method of cleaning extremely sensitive devices, such as reference reflectors and mirrors.

Infrared Sensor Card

Infrared sensor cards are available from laboratory suppliers or specialist mail order companies.

With this card you are able to control the shape of laser light emitted. The invisible laser beam is projected onto the sensor card, then becomes visible to the normal eye as a round spot.

Take care never to look into the end of a fiber or any other optical component, when they are in use. This is because the laser can seriously damage your eyes.

Preserving Connectors

Listed below are some hints on how best to keep your connectors in the best possible condition.

Making Connections

Before you make any connection you must ensure that all cables and connectors are clean. If they are dirty, use the appropriate cleaning procedure.

When inserting the ferrule of a patchcord into a connector or an adapter, make sure that the fiber end does not touch the outside of the mating connector or adapter. Otherwise you will rub the fiber end against an unsuitable surface, producing scratches and dirt deposits on the surface of your fiber.

Dust Caps and Shutter Caps

Be careful when replacing dust caps after use. Do not press the bottom of the cap onto the fiber as any dust in the cap can scratch or dirty your fiber surface.

When you have finished cleaning, put the dust cap back on, or close the shutter cap if the equipment is not going to be used immediately.

Always keep the caps on the equipment when it is not in use.

All of Agilent Technologies' lightwave instruments and accessories are shipped with either laser shutter caps or dust caps. If you need additional or replacement dust caps, contact your nearest Agilent Technologies Sales/Service Office.

Immersion Oil and Other Index Matching Compounds

Wherever possible, do not use immersion oil or other index matching compounds with your device. They are liable to impair and dirty the surface of the device. In addition, the characteristics of your device can be changed and your measurement results affected.

Cleaning Instrument Housings

Use a dry and very soft cotton tissue to clean the instrument housing and the keypad. Do not open the instruments as there is a danger of electric shock, or electrostatic discharge. Opening the instrument can cause damage to sensitive components, and in addition your warranty will be voided.

Which Cleaning Procedure should I use ?

Light dirt

If you just want to clean away light dirt, observe the following procedure for all devices:

- Use compressed air to blow away large particles.
- Clean the device with a dry cotton swab.
- Use compressed air to blow away any remaining filament left by the swab.

Heavy dirt

If the above procedure is not enough to clean your instrument, follow one of the procedures below. Please consult *"Cleaning Instructions for this Instrument"* on page 25 for the procedure relevant for this instrument.

If you are unsure of how sensitive your device is to cleaning, please contact the manufacturer or your sales distributor

How to clean connectors

Cleaning connectors is difficult as the core diameter of a single-mode fiber is only about 9 μm . This generally means you cannot see streaks or scratches on the surface. To be certain of the condition of the surface of your connector and to check it after cleaning, you need a microscope.

In the case of scratches, or of dust that has been burnt onto the surface of the connector, you may have no option but to polish the connector. This depends on the degree of dirtiness, or the depth of the scratches. This is a difficult procedure and should only be performed by a skilled person, and as a last resort as it wears out your connector.

WARNING

Never look into the end of an optical cable that is connected to an active source.

To assess the projection of the emitted light beam you can use an infrared sensor card. Hold the card approximately 5 cm from the output of the connector. The invisible emitted light is projected onto the card and becomes visible as a small circular spot.

Preferred Procedure

Use the following procedure on most occasions.

- 1 Clean the connector by rubbing a new, dry cotton swab over the surface using a small circular movement.
- 2 Blow away any remaining lint with compressed air.

Procedure for Stubborn Dirt

Use this procedure when there is greasy dirt on the connector:

- 1 Moisten a new cotton swab with isopropyl alcohol.
- 2 Clean the connector by rubbing the cotton swab over the surface using a small circular movement.
- 3 Take a new, dry soft tissue and remove the alcohol, dissolved sediment and dust, by rubbing gently over the surface using a small circular movement.
- 4 Blow away any remaining lint with compressed air.

An Alternative Procedure

A better, more gentle, but more expensive cleaning procedure is to use an ultrasonic bath with isopropyl alcohol.

- 1** Hold the tip of the connector in the bath for at least three minutes.
- 2** Take a new, dry soft tissue and remove the alcohol, dissolved sediment and dust, by rubbing gently over the surface using a small circular movement.
- 3** Blow away any remaining lint with compressed air.

How to clean connector adapters

CAUTION

Some adapters have an anti-reflection coating on the back to reduce back reflection. This coating is extremely sensitive to solvents and mechanical abrasion. Extra care is needed when cleaning these adapters.

Preferred Procedure

Use the following procedure on most occasions.

- 1 Clean the adapter by rubbing a new, dry cotton swab over the surface using a small circular movement.
- 2 Blow away any remaining lint with compressed air.

Procedure for Stubborn Dirt

Use this procedure when there is greasy dirt on the adapter:

- 1 Moisten a new cotton swab with isopropyl alcohol.
- 2 Clean the adapter by rubbing the cotton swab over the surface using a small circular movement.
- 3 Take a new, dry soft tissue and remove the alcohol, dissolved sediment and dust, by rubbing gently over the surface using a small circular movement.
- 4 Blow away any remaining lint with compressed air.

How to clean connector interfaces

CAUTION

Be careful when using pipe cleaners, as the core and the bristles of the pipe cleaner are hard and can damage the interface.

Do not use pipe cleaners on optical head adapters, as the hard core of normal pipe cleaners can damage the bottom of an adapter.

Preferred Procedure

Use the following procedure on most occasions.

- 1 Clean the interface by pushing and pulling a new, dry pipe cleaner into the opening. Rotate the pipe cleaner slowly as you do this.
- 2 Then clean the interface by rubbing a new, dry cotton swab over the surface using a small circular movement.
- 3 Blow away any remaining lint with compressed air.

Procedure for Stubborn Dirt

Use this procedure when there is greasy dirt on the interface:

- 1 Moisten a new pipe cleaner with isopropyl alcohol.
- 2 Clean the interface by pushing and pulling the pipe cleaner into the opening. Rotate the pipe cleaner slowly as you do this.
- 3 Moisten a new cotton swab with isopropyl alcohol.
- 4 Clean the interface by rubbing the cotton swab over the surface using a small circular movement.
- 5 Using a new, dry pipe cleaner, and a new, dry cotton swab remove the alcohol, any dissolved sediment and dust.
- 6 Blow away any remaining lint with compressed air.

How to clean bare fiber adapters

Bare fiber adapters are difficult to clean. Protect from dust unless they are in use.

CAUTION

Never use any kind of solvent when cleaning a bare fiber adapter as solvents can:

- Damage the foam inside some adapters.
- Deposit dissolved dirt in the groove, which can then dirty the surface of an inserted fiber.

Preferred Procedure

Use the following procedure on most occasions.

- 1 Blow away any dust or dirt with compressed air.

Procedure for Stubborn Dirt

Use this procedure when there is greasy dirt on the adapter:

- 1 Clean the adapter by pushing and pulling a new, dry pipe cleaner into the opening. Rotate the pipe cleaner slowly as you do this.

CAUTION

Be careful when using pipe cleaners, as the core and the bristles of the pipe cleaner are hard and can damage the adapter.

- 2 Clean the adapter by rubbing a new, dry cotton swab over the surface using a small circular movement.
- 3 Blow away any remaining lint with compressed air.

How to clean lenses

Some lenses have special coatings that are sensitive to solvents, grease, liquid and mechanical abrasion. Take extra care when cleaning lenses with these coatings.

Lens assemblies consisting of several lenses are not normally sealed. Therefore, use as little alcohol as possible, as it can get between the lenses and in doing so can change the properties of projection.

Preferred Procedure

Use the following procedure on most occasions.

- 1 Clean the lens by rubbing a new, dry cotton swab over the surface using a small circular movement.
- 2 Blow away any remaining lint with compressed air.

Procedure for Stubborn Dirt

Use this procedure when there is greasy dirt on the lens:

- 1 Moisten a new cotton swab with isopropyl alcohol.
- 2 Clean the lens by rubbing the cotton swab over the surface using a small circular movement.
- 3 Using a new, dry cotton swab remove the alcohol, any dissolved sediment and dust.
- 4 Blow away any remaining lint with compressed air.

How to clean instruments with a fixed connector interface

You should only clean instruments with a fixed connector interface when it is absolutely necessary. This is because it is difficult to remove any used alcohol or filaments from the input of the optical block.

It is important, therefore, to keep dust caps on the equipment at all times, except when your optical device is in use.

If you do discover filaments or particles, the only way to clean a fixed connector interface and the input of the optical block is to use compressed air.

If there are fluids or fat in the connector, please refer the instrument to the skilled personnel of Agilent's service team.

CAUTION

Only use clean, dry compressed air. Make sure that the air is free of dust, water, and oil. If the air that you use is not clean and dry, this can lead to filmy deposits or scratches on the surface of your connector interface. This will degrade the performance of your transmission system.

Never try to open the instrument and clean the optical block by yourself, because it is easy to scratch optical components, and cause them to become misaligned.

How to clean instruments with an optical glass plate

Some instruments, for example, the optical heads from Agilent Technologies have an optical glass plate to protect the sensor. Clean this glass plate in the same way as optical lenses (see [“How to clean lenses”](#) on page 41).

How to clean instruments with a physical contact interface

Remove any connector interfaces from the optical output of the instrument before you begin the cleaning procedure.

Cleaning interfaces is difficult as the core diameter of a single-mode fiber is only about 9 μm . This generally means you cannot see streaks or scratches on the surface. To be certain of the degree of pollution on the surface of your interface and to check whether it has been removed after cleaning, you need a microscope.

WARNING

Never look into an optical output, because this can seriously damage your eyesight.

To assess the projection of the emitted light beam you can use an infrared sensor card. Hold the card approximately 5 cm from the interface. The invisible emitted light is projected onto the card and becomes visible as a small circular spot.

Preferred Procedure

Use the following procedure on most occasions.

- 1 Clean the interface by rubbing a new, dry cotton swab over the surface using a small circular movement.
- 2 Blow away any remaining lint with compressed air.

Procedure for Stubborn Dirt

Use this procedure when there is greasy dirt on the interface:

- 1 Moisten a new cotton swab with isopropyl alcohol.
- 2 Clean the interface by rubbing the cotton swab over the surface using a small circular movement.
- 3 Take a new, dry soft tissue and remove the alcohol, dissolved sediment and dust, by rubbing gently over the surface using a small circular movement.
- 4 Blow away any remaining lint with compressed air.

How to clean instruments with a recessed lens interface

WARNING

For instruments with a deeply recessed lens interface (for example the Agilent 81633A and 81634A Power Sensors) do NOT follow this procedure. Alcohol and compressed air could damage your lens even further.

Keep your dust and shutter caps on when your instrument is not in use. This should prevent it from getting too dirty. If you must clean such instruments, please refer the instrument to the skilled personnel of Agilent's service team.

Preferred Procedure

Use the following procedure on most occasions.

- 1 Blow away any dust or dirt with compressed air.
If this is not sufficient, then
- 2 Clean the interface by rubbing a new, dry cotton swab over the surface using a small circular movement.
- 3 Blow away any remaining lint with compressed air.

Procedure for Stubborn Dirt

Use this procedure when there is greasy dirt on the interface, and using the preferred procedure is not sufficient. Using isopropyl alcohol should be your last choice for recessed lens interfaces because of the difficulty of cleaning out any dirt that is washed to the edge of the interface:

- 1 Moisten a new cotton swab with isopropyl alcohol.
- 2 Clean the interface by rubbing the cotton swab over the surface using a small circular movement.
- 3 Take a new, dry soft tissue and remove the alcohol, dissolved sediment and dust, by rubbing gently over the surface using a small circular movement.
- 4 Blow away any remaining lint with compressed air.

How to clean optical devices which are sensitive to mechanical stress and pressure

Some optical devices, such as the Agilent 81000BR Reference Reflector, which has a gold plated surface, are very sensitive to mechanical stress or pressure. Do not use cotton swabs, soft tissues or other mechanical cleaning tools, as these can scratch or destroy the surface.

Preferred Procedure

Use the following procedure on most occasions.

- 1 Blow away any dust or dirt with compressed air.

Procedure for Stubborn Dirt

To clean devices that are extremely sensitive to mechanical stress or pressure you can also use an optical clean polymer film. This procedure is time-consuming, but you avoid scratching or destroying the surface.

- 1 Put the film on the surface and wait at least 30 minutes to make sure that the film has had enough time to dry.
- 2 Remove the film and any dirt with special adhesive tapes.

Alternative Procedure

For these types of optical devices you can often use an ultrasonic bath with isopropyl alcohol. Only use the ultrasonic bath if you are sure that it won't cause any damage any part of the device.

- 1 Put the device into the bath for at least three minutes.
- 2 Blow away any remaining liquid with compressed air.

If there are any streaks or drying stains on the surface, repeat the cleaning procedure.

How to clean metal filters or attenuator gratings

This kind of device is extremely fragile. A misalignment of the grating leads to inaccurate measurements. Never touch the surface of the metal filter or attenuator grating. Be very careful when using or cleaning these devices. Do not use cotton swabs or soft tissues, as there is the danger that you cannot remove the lint and that the device will be destroyed by becoming mechanically distorted.

Preferred Procedure

Use the following procedure on most occasions.

- 1 Use compressed air at a distance and with low pressure to remove any dust or lint.

Procedure for Stubborn Dirt

Do not use an ultrasonic bath as this can damage your device.

Use this procedure when there is greasy dirt on the device:

- 1 Put the optical device into a bath of isopropyl alcohol, and wait at least 10 minutes.
- 2 Remove the fluid using compressed air at some distance and with low pressure. If there are any streaks or drying stains on the surface, repeat the whole cleaning procedure.

Additional Cleaning Information

The following cleaning procedures may be used with other optical equipment:

- How to clean bare fiber ends
- How to clean large area lenses and mirrors

How to clean bare fiber ends

Bare fiber ends are often used for splices or, together with other optical components, to create a parallel beam. The end of a fiber can often be scratched. You make a new cleave. To do this:

- 1 Strip off the cladding.
- 2 Take a new soft tissue and moisten it with isopropyl alcohol.
- 3 Carefully clean the bare fiber with this tissue.
- 4 Make your cleave and immediately insert the fiber into your bare fiber adapter in order to protect the surface from dirt.

How to clean large area lenses and mirrors

Some mirrors, as those from a monochromator, are very soft and sensitive. Therefore, never touch them and do not use cleaning tools such as compressed air or polymer film.

Some lenses have special coatings that are sensitive to solvents, grease, liquid and mechanical abrasion. Take extra care when cleaning lenses with these coatings.

Lens assemblies consisting of several lenses are not normally sealed. Therefore, use as little liquid as possible, as it can get between the lenses and in doing so can change the properties of projection.

Preferred Procedure

Use the following procedure on most occasions.

- 1 Blow away any dust or dirt with compressed air.

Procedure for Stubborn Dirt

Use this procedure when there is greasy dirt on the lens:

CAUTION

Only use water if you are sure that there is no other way of cleaning your optical device without causing corrosion or damage.

Only use water if you are sure that there is no other way of cleaning your optical device without causing corrosion or damage. Do not use hot water, as this may cause mechanical stress, which can damage your optical device.

Ensure that your liquid soap has no abrasive properties or perfume in it. You should also avoid normal washing up liquid, as it can cover your device in an iridescent film after it has been air dried.

Some lenses and mirrors also have a special coating, which may be sensitive to mechanical stress, or to fat and liquids. For this reason we recommend you do not touch them.

If you are not sure how sensitive your device is to cleaning, please contact the manufacturer or your sales distributor.

- 1 Moisten the lens or the mirror with water.
- 2 Put a little liquid soap on the surface and gently spread the liquid over the whole area.
- 3 Wash off the emulsion with water, being careful to remove it all, as any remaining streaks can impair measurement accuracy.
- 4 Take a new, dry soft tissue and remove the water, by rubbing gently over the surface using a small circular movement.
- 5 Blow away remaining lint with compressed air.

Alternative Procedure A

To clean lenses that are extremely sensitive to mechanical stress or pressure you can also use an optical clean polymer film. This procedure is time-consuming, but you avoid scratching or destroying the surface.

- 1 Put the film on the surface and wait at least 30 minutes to make sure that the film has had enough time to dry.
- 2 Remove the film and any dirt with special adhesive tapes.

Alternative Procedure B

If your lens is sensitive to water then:

- 1 Moisten the lens or the mirror with isopropyl alcohol.
- 2 Take a new, dry soft tissue and remove the alcohol, dissolved sediment and dust, by rubbing gently over the surface using a small circular movement.

- 3 Blow away remaining lint with compressed air.

Other Cleaning Hints

Selecting the correct cleaning method is an important element in maintaining your equipment and saving you time and money. This Appendix highlights the main cleaning methods, but cannot address every individual circumstance.

This section contain some additional hints which we hope will help you further. For further information, please contact your local Agilent Technologies representative.

Making the connection

Before you make any connection you must ensure that all lightwave cables and connectors are clean. If not, then use the appropriate cleaning methods.

When you insert the ferrule of a patchcord into a connector or an adapter, ensure that the fiber end does not touch the outside of the mating connector or adapter. Otherwise, the fiber end will rub up against something which could scratch it and leave deposits.

Lens cleaning papers

Some special lens cleaning papers are not suitable for cleaning optical devices like connectors, interfaces, lenses, mirrors and so on. To be absolutely certain that a cleaning paper is applicable, please ask the salesperson or the manufacturer.

Immersion oil and other index matching compounds

Do not use immersion oil or other index matching compounds with optical sensors equipped with recessed lenses. They are liable to dirty the detector and impair its performance. They may also alter the property of depiction of your optical device, thus rendering your measurements inaccurate.

Cleaning the housing and the mainframe

When cleaning either the mainframe or the housing of your instrument, only use a dry and very soft cotton tissue on the surfaces and the numeric pad.

Never open the instruments as they can be damaged. Opening the instruments puts you in danger of receiving an electrical shock from your device, and renders your warranty void.

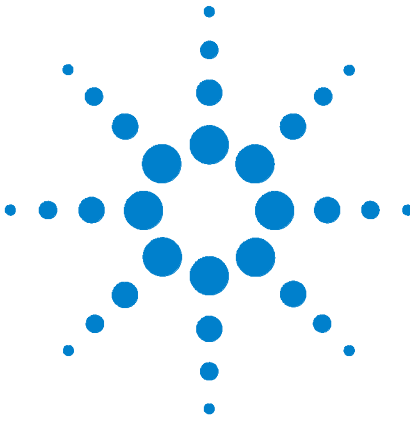

5 Specifications

Agilent 81663A DFB Laser Source Module is produced to the ISO 9001 international quality system standard as part of Agilent's commitment to continually increasing customer satisfaction through improved quality control.

Specifications describe the module's warranted performance. Supplementary performance characteristics describe the module's non-warranted typical performance.

Because of the modular nature of the instrument, these performance specifications apply to the module rather than the mainframe unit.



Definition of Terms

This section defines terms that are used both in this chapter and “[Performance Tests](#)” on page 17.

Generally, all specifications apply for the given environmental conditions and after warmup time.

Measurement principles are indicated. Alternative measurement principles of equal value are also acceptable.

Wavelength tuning range

The range of wavelengths for which the specifications apply, where the relevant center wavelength is defined as the center of the tuning range.

Conditions: at specified conditions and coherence control off.

Measurement: with wavelength meter.

Wavelength display resolution

The smallest possible displayed wavelength increment or decrement.

Wavelength repeatability

The random uncertainty in reproducing the wavelength after detuning and re-setting the wavelength. The wavelength repeatability is \pm half the span between the maximum and the minimum value of all measured wavelengths.

Conditions: uninterrupted DFB laser source module output power, constant power level, coherence control off, controlled environment as specified.

Measurement: with wavelength meter. Averaging time given by wavelength meter, \square 1 s.

NOTE

The long-term wavelength repeatability can be obtained by taking the wavelength repeatability and wavelength stability into account.

Wavelength stability

The change of wavelength during given time span, expressed as \pm half the span between the maximum and the minimum of all measured wavelengths.

Conditions: uninterrupted DFB laser source module output power, constant wavelength and power level settings, coherence control off, controlled environment and time span as specified.

Measurement: with wavelength meter. Averaging time given by wavelength meter \square 1 s.

Max. output power

The highest optical power obtainable at the end of a single-mode fiber patchcord.

Conditions: at default wavelength.

Measurement: with power meter at the end of a single-mode fiber patchcord.

Power CW stability

The change of the power level during given time span, expressed as \pm half the span (in dB) between the highest and lowest measured power.

Conditions: uninterrupted DFB laser source module output power, constant wavelength and power level settings, controlled environment and time span as specified.

Measurement: with optical power meter.

Sidemode suppression ratio (SMSR)

The ratio of the optical power of the main mode to the optical power of the highest sidemode expressed in dB.

Conditions: at a specified output power and wavelength, coherence control off.

Measurement: with the optical spectrum analyzer Agilent 81642B, resolution bandwidth 0.06 nm.

Polarization extinction ratio (PER)

The ratio of optical power in the slow axis of the polarization-maintaining fiber to optical power in the fast axis.

Measurement: with a polarization analyzer by mechanically stressing the Panda fiber.

Coherence control

Linewidth broadening of optical signal by internal laser modulation.

Modulation, digital

Output signal is modulated with 50% duty cycle by internal on / off switching of the laser current. Switching frequencies as specified.

ON- switching with fast output power stabilization

When the laser is switched on after the specified warm-up time the output power will settle within the specified time to comply with the power stability specifications.

Tuning Speed

Maximum time required to change the wavelength of the optical signal between the extreme ends of the specified wavelength tuning range.

DFB Source Module Specifications

Specifications apply to maximum power setting after warm-up time.

	Agilent 81663A Option #131	Agilent 81663A Option #149	Agilent 81663A Option #151	Agilent 81663A Option #155	Agilent 81663A Option #162
Type	CW DFB Laser with built-in isolator				
Center Wavelength ^{a b}	1310 nm ± 5 nm	1490 nm ± 3 nm	1510 nm ± 3 nm	1550 nm ± 3 nm	1625 nm ± 3 nm
Tuning Range	typ. > ±500 pm				
Display Resolution	10 pm				
Repeatability ^c	±5 pm (typ. ±2 pm)				
Stability (15min.) ^c	± 5 pm (typ ±2 pm)				
Stability (24h) ^c	typ. ±5 pm				
Fiber type	Panda PMF 9 / 125 μm				
Output Connector ^d	Compatible to angled contact APC, ASC, DIN47256/4108				
Power					
Max. Output ^e	typ. > +13 dBm (20 mW)				
CW Stability (15min) ^c	typ. ±0.003 dB				
CW Stability (24 h) ^c	typ. ±0.01 dB				
Side Mode Suppression Ratio (SMSR) ^e	typ. 45 dB				
Polarization Extinction Ratio (PER)	typ. > 20 dB				
Dimensions (H x W x D)	75 mm H x 32 mm W x 335 mm D (2.8" x 1.3" x 13.2")				
Weight	0.5kg				
Recalibration Period	2 year				
Operating Temperature	15°C to 35 °C				
Warm-up time ^f	60 min				

a Center wavelength is shown on display as default.

b Via GPIB tuning resolution < 10 pm.

c Controlled environment $\Delta T = \pm 1$ °C.

d Connector interface not included.

e At maximum power setting and default wavelength at the end of a 2 m SM patchcord.

f If previously stored at the same temperature 20 min.

Supplementary Performance Characteristics

Internal digital modulation mode: Free selection 200 Hz to 100 kHz.

All output signals are pulse shaped, duty cycle 50%.

Internal variable coherence control for linewidth broadening.

ON-switching with fast output power stabilization <20 s.

Output power "attenuation" at default wavelength 6 dB in steps of 0.1 dB.

Tuning speed over full range 30 s.

Polarization maintaining fiber orientation: TE mode in slow axis, in line with connector key.

Index

A

Accessories, 15

C

Connectors

- angled contact, 12
- straight contact, 12

G

Getting Started, 7

- Enable/Disable Laser Output, 11
- Front Panel, 11
- What is a DFB Laser Source Module?, 11

I

Initial Safety Information, 10

ITU Channel Options, 16

O

Optical Output, 11

P

Performance Tests, 17

- Agilent 8166_A, 21
- All Wavelength Tests, 19
- Equipment Required, 18
- Instructions, 19
- Test Failure, 18
- Test Record, 18
- Wavelength Repeatability, 19
- Wavelength Stability, 20
- Polarization Maintaining Fiber, 11

R

Recommended Connector Interfaces, 16

S

Safety

- information for laser source, 10
- Specifications, 53
 - DFB Source Module, 57
- Supplementary Performance Characteristics, 57

W

Wavelength Accuracy Below Maximum Power, 13

© Agilent Technologies 2010

May 2010
Eighth Edition

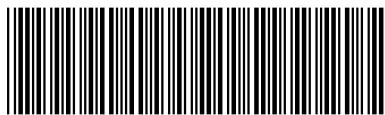

81661-90A15

